

GOLD STANDARD® CALIBRATION SYSTEM (U.S. & METRIC)

FEATURES AND BENEFITS

- Capacities from 55K and 100K lbf
- Less than 0.04% uncertainty
- Fully automated system will reduce calibration time by 50% to 90%
- Automated tension and compression calibration runs can be completed in less than 5 minutes
- 4-post design provides superior stability throughout the calibration
- Innovative fixturing allows for tension and compression calibration without changing setup
- 12 inches of clearance between posts allows for easy load cell installation and removal
- Accurate and reliable load control achieved by proprietary load feedback design
- Testing and reporting per ASTM E74, ISO 376, and EN100002-3 standards
- Automatically produces standard reports, graphs, and performance parameter calculations
- Ability to customize reports and graphs
- Automatically archives data

The Interface Gold Standard® Calibration System using the Interface Gold or Platinum Standard® Load Cells ensures a metrology system of the highest accuracy and lowest uncertainty available.

The Gold Standard® Calibration System includes:

- Precision load frame
- Integrated control and measurement system
- Integrated computer system with Interface Gold Standard® Calibration Software

OPTIONS

- Interface Gold or Platinum Standard® reference load cells
- Thread adapters for easy set-up and use
- Additional input channels for multiple bridge load cells or transducers with high level outputs
- Special threads and calibration adapters
- CX Series Precision mV/V transfer standard for system calibration
- On-site training

SOFTWARE

- Load points can be preset as required per your test specifications
- The ICS-202 Gold Standard® Calibration Software ICS-202 Gold Standard® Calibration Software will provide exact load output at specific load points
- Calibration results from other runs can be compared, measured, and displayed with current run results

STANDARD CONFIGURATION



Model LF1-55K-1-5 (Shown)

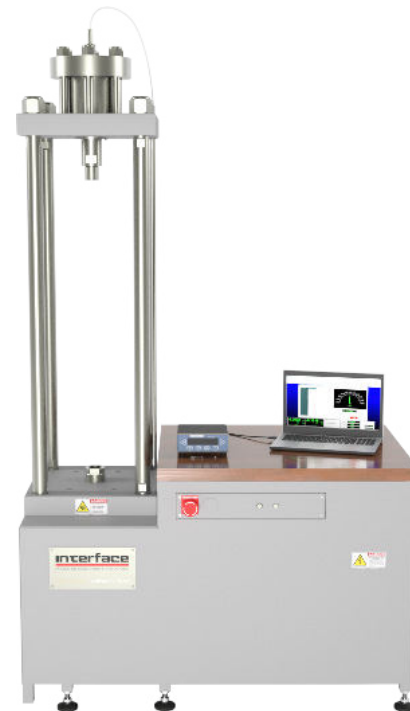

Model LF1-100K-1-7 (Shown)



GOLD STANDARD® CALIBRATION SYSTEM (U.S. & METRIC)

SPECIFICATIONS

LOAD FRAME				
Model				
Capacity	lbf	55K	55K	100K
	kN	244	244	444
Max Working Height	in	30	44	44
	mm	762	1117.6	1117.6
Weight - TYP	lbs	2400	2500	2650
	kg	1088.6	1133.9	1202
Type	Four Column, Dual Action Hydraulic			
Test Type	Compression or Tension			
Piston Stroke	in	6		
	mm	152.4		
Measurement Range	2% to 100% of Rated Load Frame Capacity			
INSTALLATION REQUIREMENTS				
Power	208/240 VAC, 50/60 Hz, Single Phase, 30 Amp Circuit			
HYDRAULICS				
Oil Capacity	gal	5 - 10		
	l	18.9 - 37.8		
Oil Type	ISO 32			
Oil Temperature	Indicator with automatic over temperature cutoff			
Oil Level	Indicator with automatic low level cutoff			
LOAD FRAME CONTROLS				
Force Control	Closed loop, PID			
Piston Sensor	LVDT			
Slack Adapter Range	in	+/- 0.25		
	mm	+/- 6.35		
Setpoint Input	+/- 10 VDC			
Force Limit	User Selectable, requires acknowledgment			
Setpoint Interface	USB to +/- 10 VDC Converter			
GOLD STANDARD SOFTWARE				
Operating System	Windows 10			
Hardware Requirement				
Reports	ASTM E74, ISO 376, Custom			
Shunt Calibration	Automatic or Manual			
Calibration Control	Automatic			
Curve Fit	Least Squares Method			
Calibration Management	Compare Current and Previous Test Results			
SHIPPING				
Shipping Weight - Nominal	lbs	2600	2700	2850
	kg	1179.3	1224.6	1292.7
Crate Dimensions - Typ W x H x D	in	72 X 90 X 48	72 X 104 X 48	72 X 104 X 48
	mm	1828.8 x 2286 x 1219.2	1828.8 x 2641.6 x 1219.2	1828.8 x 2641.6 x 1219.2

International System of Units (SI) dimensions and capacities are provided for conversion only. Standard products have U.S. capacities and dimensions. SI capacities available upon special request and at an additional cost.

GOLD STANDARD® CALIBRATION SYSTEM (U.S. & METRIC)

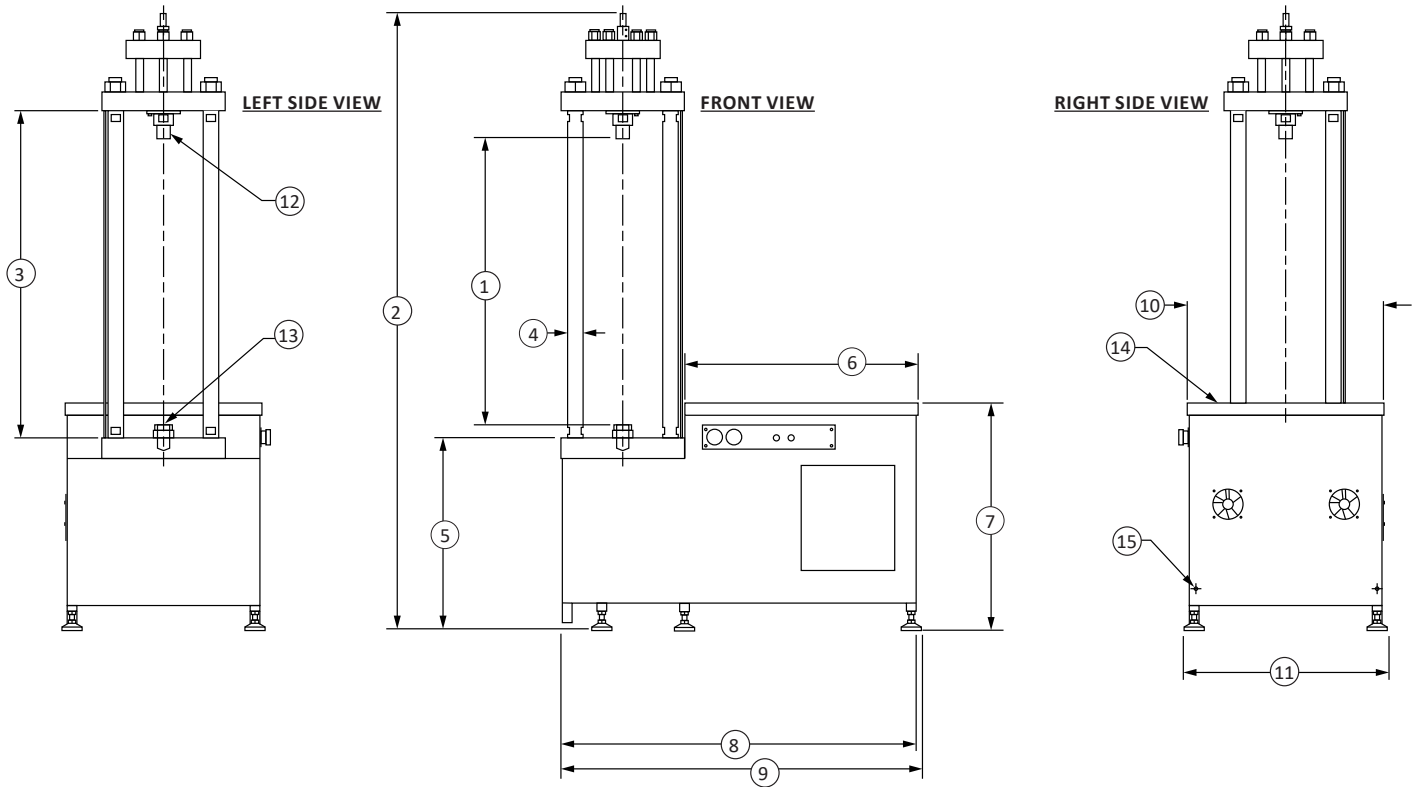

DIMENSIONS

See Drawing	Model					
	LF1-55K-1-5		LF1-55K-1-6		LF1-100K-1-7	
	Capacity					
	U.S. (lbf)	Metric (kN)	U.S. (lbf)	Metric (kN)	U.S. (lbf)	Metric (kN)
	55K	244	55K	244	100K	444
	in	mm	in	mm	in	mm
(1)	24.4/30.4 (MIN/MAX)	619.76/772.16 (MIN/MAX)	38.4/44.4 (MIN/MAX)	975.36/1127.86 (MIN/MAX)	38.4/44.4 (MIN/MAX)	975.36/1127.86 (MIN/MAX)
(2)	82.0 (84.0 installed)	2082.8 (2133.6 installed)	96.0 (98.0 installed)	2438.4 (2489.2 installed)	96.0 (98.0 installed)	2438.4 (2489.2 installed)
(3)	36.5	927.1	50.5	1282.7	50.5	1282.7
(4)	Ø2.25 TYP.	Ø57.15 TYP.	Ø2.25 TYP.	Ø57.15 TYP.	Ø2.25 TYP.	Ø57.15 TYP.
(5)	29.688	754.08	29.688	754.08	29.688	754.08
(6)	36.0	914.4	36.0	914.4	36.0	914.4
(7)	35.063	890.6	35.063	890.6	35.063	890.6
(8)	55.0	1397.0	55.0	1397.0	55.0	1397.0
(9)	55.719	1415.26	55.719	1415.26	55.719	1415.26
(10)	30.0	762.0	30.0	762.0	30.0	762.0
(11)	31.25	793.75	31.25	793.75	31.25	793.75
(12)	Slack Adapter Assembly: 2-12 Male Thread, 3 (76.2) Dia. Rod, Vertical Range 0.5					
(13)	2-12 UN-2B Thread 3 (76.2) Deep					
(14)	Maple Table Top 36.0 x 30.0 x 1.75 (914.4 x 762.0 x 44.45)					
(15)	½-13 UNC CL2B Thread 1.5 Deep 2 - holes					

GOLD STANDARD® CALIBRATION SYSTEM (U.S. & METRIC)

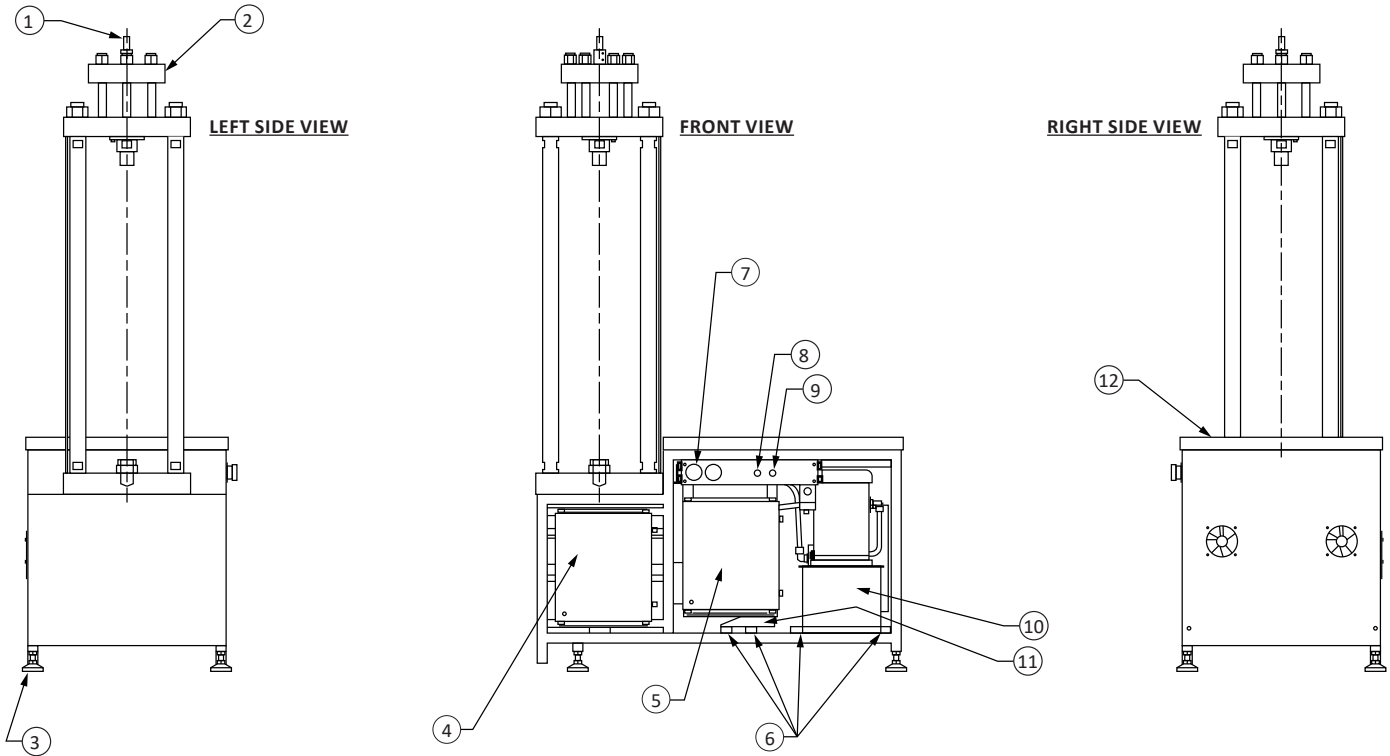

COMPONENTS

See Drawing	Model					
	LF1-55K-1-5		LF1-55K-1-6		LF1-100K-1-7	
	Capacity					
	U.S. (lbf)	Metric (kN)	U.S. (lbf)	Metric (kN)	U.S. (lbf)	Metric (kN)
	55K	244	55K	244	100K	444
(1)	LVDT Mounting Bracket					
(2)	Slack Adapter Cover/Support Assembly					
(3)	Swivel Leveling Mount					
(4)	Delta Electrical Enclosure					
(5)	Hydraulic Power Unit (HPU) Electrical Enclosure					
(6)	Oil Resistant Vibration Damping Mount					
(7)	Emergency Stop Button					
(8)	Activate/De-Activate Button					
(9)	Down Button					
(10)	Hydraulic Power Unit (HPU)					
(11)	Power Unit Chiller					
(12)	Maple Table Top					