

# General purpose accelerometer

## 786B-10

### SPECIFICATIONS

Sensitivity, $\pm 10\%$ , 25°C		100 mV/g
Acceleration range, VDC > 25 V		80 g peak
Amplitude nonlinearity		1%
Frequency response:	$\pm 5\%$	3 - 5,000 Hz
	$\pm 10\%$	1 - 9,000 Hz
	$\pm 3$ dB	0.5 - 14,000 Hz
Resonance frequency		30 kHz
Transverse sensitivity, max		5% of axial
Temperature response:	-25°C	-10%
	+120°C	+10%
Power requirement:		
Voltage source		18 - 30 VDC
Current regulating diode		2 - 10 mA
Electrical noise, equiv. g:		
Broadband	2.5 Hz to 25 kHz	700 $\mu$ g
Spectral	10 Hz	10 $\mu$ g/ $\sqrt{\text{Hz}}$
	100 Hz	5 $\mu$ g/ $\sqrt{\text{Hz}}$
	1,000 Hz	5 $\mu$ g/ $\sqrt{\text{Hz}}$
Output impedance		100 $\Omega$
Bias output voltage		12 VDC
Grounding		case isolated, internally shielded
Temperature range		-50° to +120°C
Vibration limit		500 g peak
Shock limit		5,000 g peak
Electromagnetic sensitivity, equiv. g, max		70 $\mu$ g/gauss
Sealing		hermetic
Base strain sensitivity, max		0.0002 g/ $\mu$ strain
Sensing element design		PZT, shear
Weight		90 grams
Case material		316L stainless steel
Mounting		1/4-28 UNF tapped hole
Mating connector		MIL-5015 style
Recommended cabling		J10 / J9T2A

Accessories supplied: SF6 mounting stud (metric mounting available); calibration data (level 2)



### Key features

- Long-lasting reliability at an affordable price
- Manufactured in ISO 9001 facility

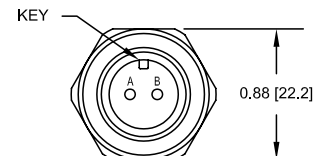
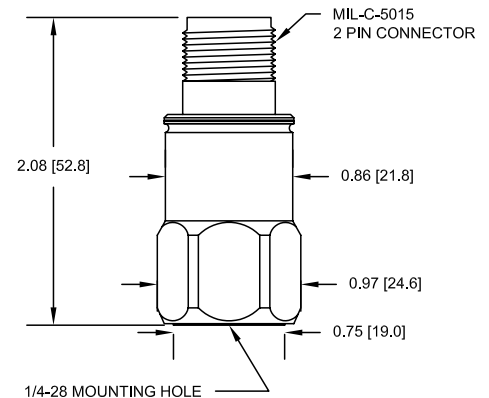

Connections	
Function	Connector pin
power/signal	A
common	B
ground	shell



Note: Due to continuous process improvement, specifications are subject to change without notice.  
This document is cleared for public release.